

OWNERS MANUAL

MODEL:

30 HOTDOG

Roller Grill

PART NUMBER:

62030

115 volts, 60 hz



WARNING ELECTRICAL SHOCK HAZARD.

FAILURE TO FOLLOW THESE INSTRUCTIONS COULD RESULT IN SERIOUS INJURY OR DEATH.

WARNING: Handling the cord on this product may expose you to lead, a chemical known to the State Of California to cause cancer and birth defects or other reproductive harm. WASH HANDS AFTER HANDLING.

1. Electrical ground is required on this appliance.
2. Do not modify the power supply cord plug. If it does not fit the outlet, have a proper outlet installed by a qualified electrician.
3. Do not use an extension cord with this appliance.
4. Check with a qualified electrician if you are in doubt as to whether the appliance is properly grounded.

SAFETY INSTRUCTIONS

1. Plug electrical cord into a certified electrical outlet with a corresponding voltage rating as listed on the machine model labels.
2. Always unplug the electric cord when appliance is not in use and before cleaning, adjusting or maintaining this steamer. Do not operate with a damaged cord or plug or after the machine malfunctions, has been dropped or damaged. Use authorized service for examination, electrical or mechanical adjustment or repair.
3. This equipment will be HOT during use and for a short time after it is turned off BE CAREFUL. To avoid burns, do not let bare skin touch hot surfaces. If provided, use handles when moving this appliance. Keep combustible materials away from appliance.
4. Extreme caution is necessary when any appliance is used by or near children and whenever the appliance is left operating and unattended.
5. This appliance is not intended for use in wet locations. Never locate appliance where it may fall into a water container. Do not insert or allow foreign objects to enter any ventilation or exhaust opening as this may cause an electrical shock, fire or damage to the appliance.

CLEANING SAFETY INSTRUCTION

1. Turn control off and unplug the power cord. Avoid splashing water onto control.
2. Do not clean this appliance with a water jet or immerse in water or other liquid.



OPERATING INSTRUCTIONS

1. Plug the machine into a properly grounded 120 volt power supply.
2. Load the roller grill with the desired amount of hotdogs by placing the hotdogs on the rollers. The front 6 rollers are controlled by the left thermostat and the back 5 rollers are controlled by the right thermostat.
3. You can adjust the temperature of the front rollers and rear rollers so that you can either “cook” or “hold” on either set of rollers. It is most common to cook on the rear rollers and hold on the front.
4. Turn on the “**Roller Switch**” and set the thermostats to the desired settings for cooking or holding. The rollers will begin to rotate when the switch is activated and the thermostats will now be active. The thermostats will not produce heat unless the Roller Switch is on.
5. A normal size hotdog should be completely cooked in about 10-15 minutes. Cook time will be slightly longer for larger hotdogs.
6. Once the hotdogs have been cooked you can either adjust the thermostat to a lower setting to hold at serving temperature or move them from the “cooking” rollers to the “holding” rollers. This will prevent the hotdogs from over-cooking.
7. When you are done using the machine make sure to turn off the Roller switch.
8. **CAUTION:** Use tongs to remove hotdogs from the grill as the product and rollers will be hot to the touch.
9. In Self-Serve environments it is recommended to equip your grill with the Benchmark USA sneeze Guard (part No. 64030). An optional Bun Box that sits below the grill is also available (part No. 65030).

DIAL TEMPERATURE SETTINGS

Approximate temperatures of the rollers at the following settings.

Note: your temperatures may vary slightly due to heating environmental conditions:

Dial Setting	Roller Temperature
LO	95 F
2	105 F
3	130 F
4	160 F
5	220 F
6	280 F
HI	350 F

CLEANING THE MACHINE

1. **At the end of day:** Turn the machine off using the master switch. Remove any remaining hotdogs from the grill.
2. Turn on the rollers and set the thermostats to “OFF” setting. The rollers will now be rotating without any heat being applied.
3. Apply slight pressure to the rollers with a clean, damp cloth as the rollers rotate. (**Note: *do not use any abrasive materials as it could scratch the polished rollers***). Slide the cloth back and forth across each of the rollers until all of the surfaces have been cleaned.
4. Remove the drip tray below the rollers and in a sink clean it thoroughly using a mild detergent and water.
5. Wipe down the remaining surfaces of the grill with a clean, damp cloth. Do not get any water on the control panel as the electricals could become damaged by water.
6. After the components have been cleaned, re-assemble the machine as outlined above.

ASSEMBLY

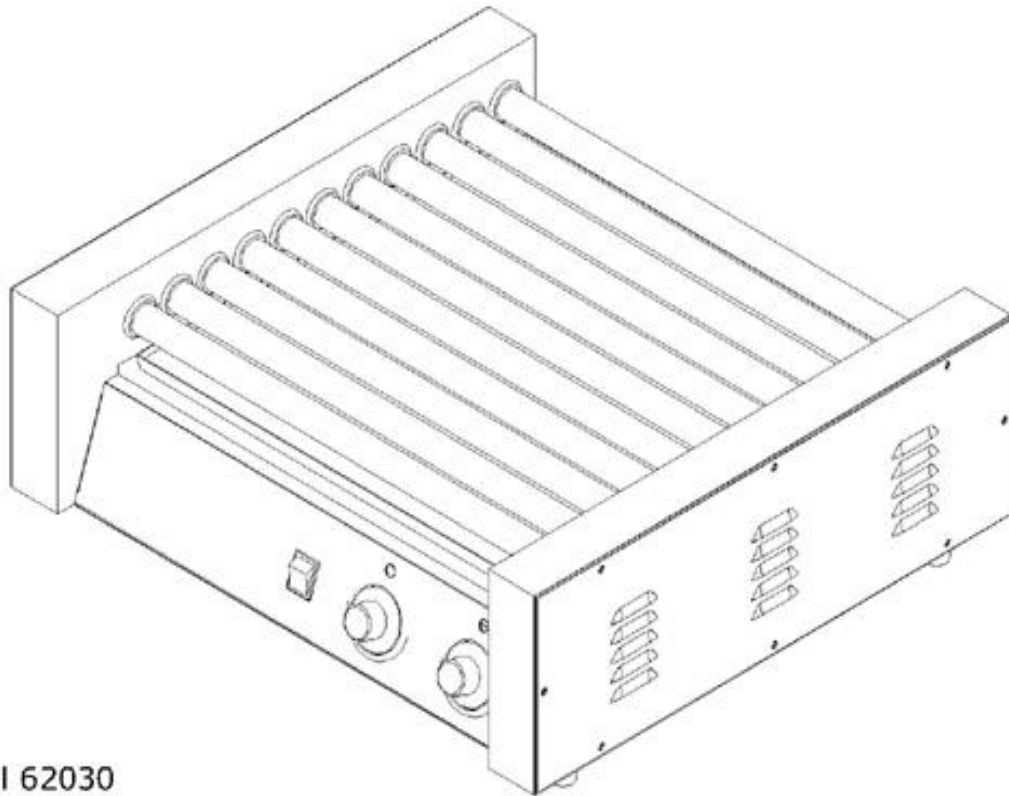

Model 62030

WIRING DIAGRAM

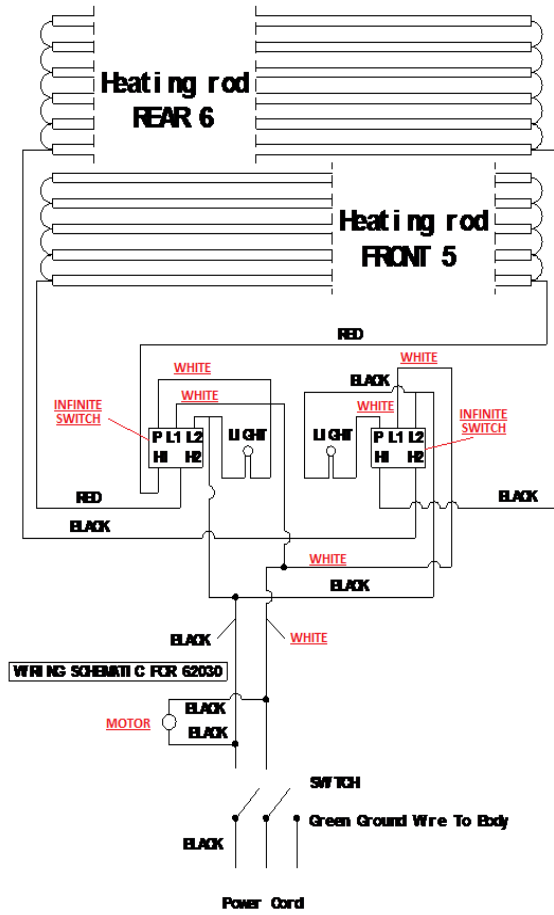

WIRING SCHEMATIC

ELECTRICAL RATINGS

Volts: 120
 Watts: 1100
 Amps: 9.2
 Hz: 60

ASSEMBLY

(complete parts list on page 7)

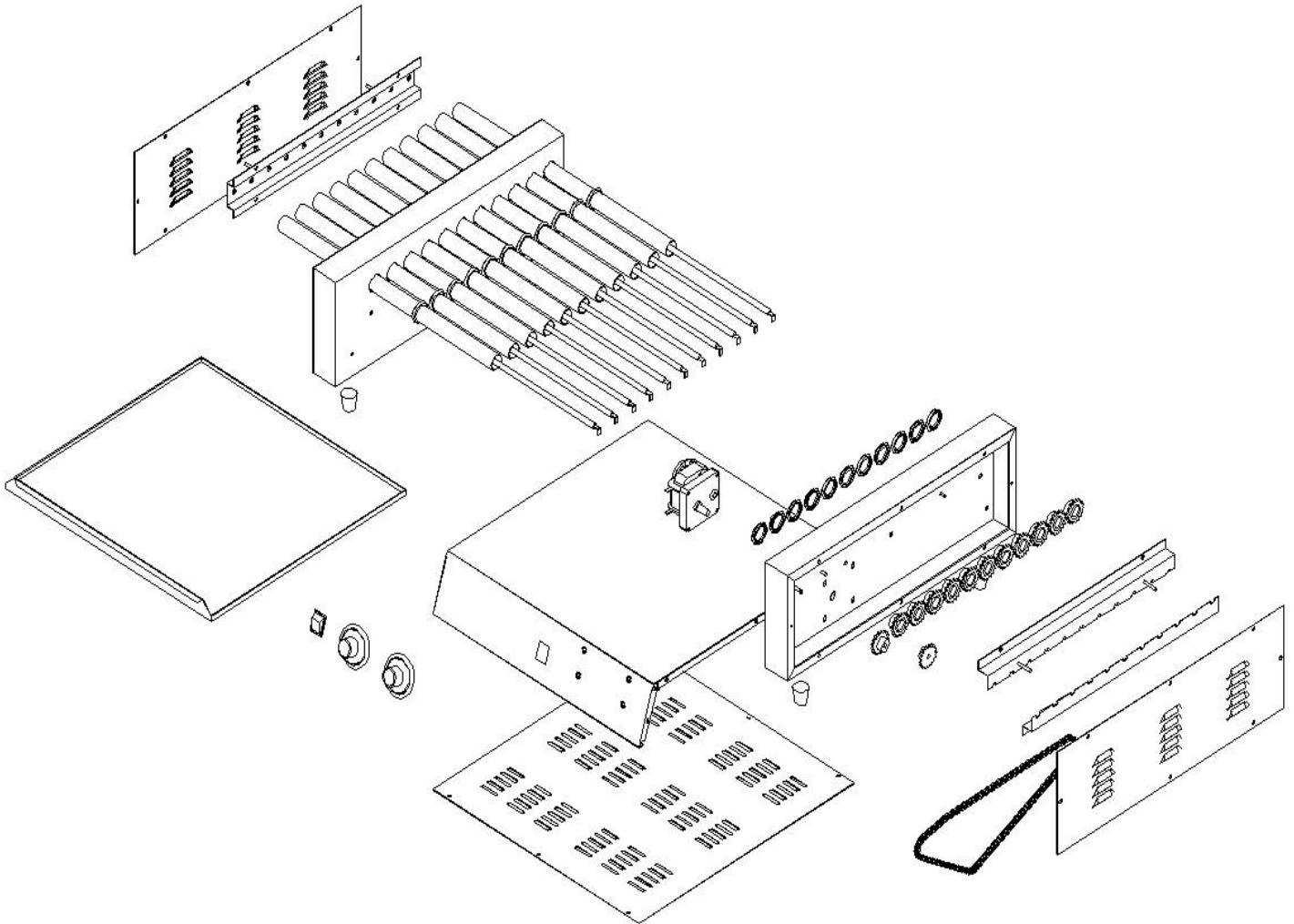

PARTS

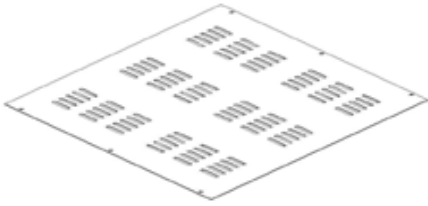

Bottom Panel #6301



Chain #6302

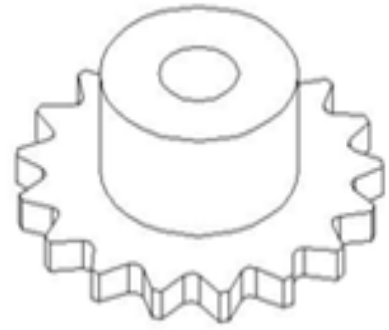

Gear #6303



Heater #6304

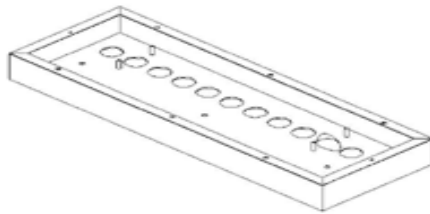

Right Panel #6305

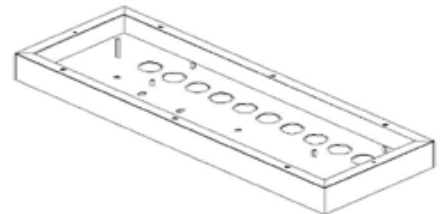

Left Panel #6306

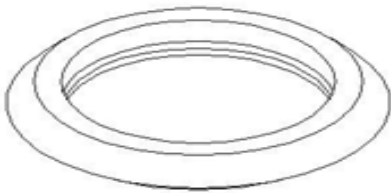

Roller Seal #6307

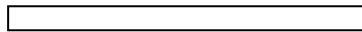

Roller Tube #6308

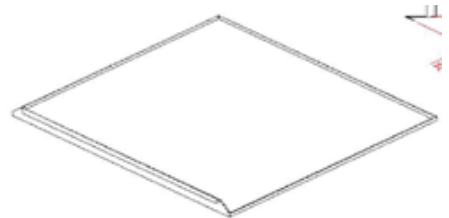

Drip Tray #6309

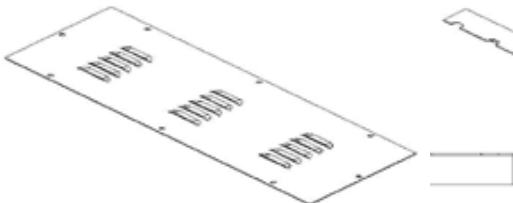

Side Cover #6310

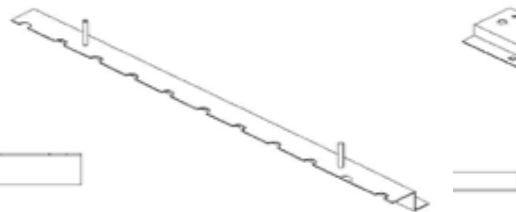

Right Heater Guide #6311

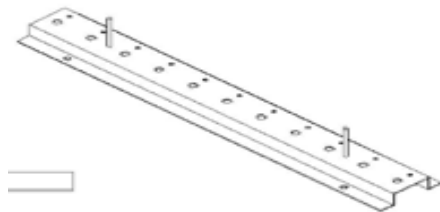

Left Heater Guide #6312

PARTS LIST

P/N	Description
6301	Bottom Panel
6302	Drive Chain
6303	Gear
6304	Heater
6305	Right Panel
6306	Left Panel
6307	Roller Seal
6308	Roller Tube
6309	Drip Tray
6310	Side Cover
6311	Right Heater Guide
6312	Left Heater Guide
6313	Thermostat
6314	Roller Switch
6315	Power Cord
6317	Strain Relief
6318	Rubber Foot
6319	Motor
6320	Base

To Order Parts Contact:

Benchmark USA, Inc.

25-J Brookfield Oaks Dr.

Greenville SC 29607 USA

Tel: 877-432-5500

Fax: 864-312-5505

Email: parts@benchmarkusainc.com



Three Year Warranty

THE WARRANTY:

Benchmark USA warrants the original purchaser of new food equipment manufactured by Benchmark USA to be free from defects in material or workmanship from the date of the original purchase for a period of three years.

WHO IS COVERED BY THIS WARRANTY:

The original purchaser who has provided proper proof of the original retail purchase and all other requested information.

WHAT IS WARRANTIED:

The obligation of Benchmark USA under this warranty is limited to the replacement of any parts or components that in the opinion of Benchmark USA are defective, F.O.B. the factory, or at any other location that Benchmark USA may designate.

WHAT VOIDS THE WARRANTY:

1. Any piece of equipment that has been installed, operated or maintained inconsistently with Benchmark USA operating instructions.
2. Any part or component that has been modified, changed or altered from its original configuration.
3. Any electrical component that has been damaged due to submergence in any liquid.
4. Any part or component that has been subject to abuse, misuse, neglect or accidents.

EXTENT OF WARRANTY:

Any defective component, part or assembly returned to Benchmark USA will be replaced by Benchmark USA. Benchmark USA will not be responsible for any expenses incurred by the customer under the terms of this warranty, nor shall it be responsible for any damages either consequential, special, contingent, or otherwise; or expenses or injury arising directly or indirectly from the use of a Benchmark USA product. Any component, part or assembly returned to Benchmark USA must be returned at the customers expense along with proof of purchase. Benchmark USA reserves the right to determine whether the terms of this warranty have been properly complied with. In the event that the terms are not complied with, Benchmark USA shall be under no obligation to honor this warranty.